

Engines for mobile machinery



The engine company.



Facts

created by DEUTZ

It all started with **1** great idea. Nicolaus August Otto invented the **4** stroke engine principle, thus laying the foundations for the global motorized society. Today, we look after our customers with over **800** sales and service partners in **130** countries worldwide supported by **4300** highly-trained and motivated DEUTZ employees. The increased use today of construction machinery worldwide in improving productivity is enormous. **82** years ago when the Empire State was built in New York a peak of **4500** people worked on its construction, but when London's Gherkin, of a similar size, was built in **8** years ago a maximum of **500** were employed. This illustrates clearly the high level of mechanization now used worldwide in construction. DEUTZ engines power over **100,000** new construction machines annually and this has made the 'DEUTZ brand' a global industry standard.

Engines

EU Stage II / US EPA Tier 2 | EU Stage III A / US EPA Tier 3

The above data is given for the purpose of information only and does not represent binding values.

DEUTZ engines have had a legendary reputation all around the world for nearly 150 years now. Above all, it's their reliability and long service life that have been the foundations of this popularity. This is as true today as it has always been. From a 4-cylinder aspirated engine right up to an 8-cylinder turbocharged engine – DEUTZ guarantees robust drives.

We offer our diesel engines in all the emission stages required to meet the needs of our customers around the world.



D/TD/TCD 2011 23–75 kW | 31–101 hp



FL 912/914 32–130 kW | 43–174 hp
D/TCD 914 43–130 kW | 58–174 hp

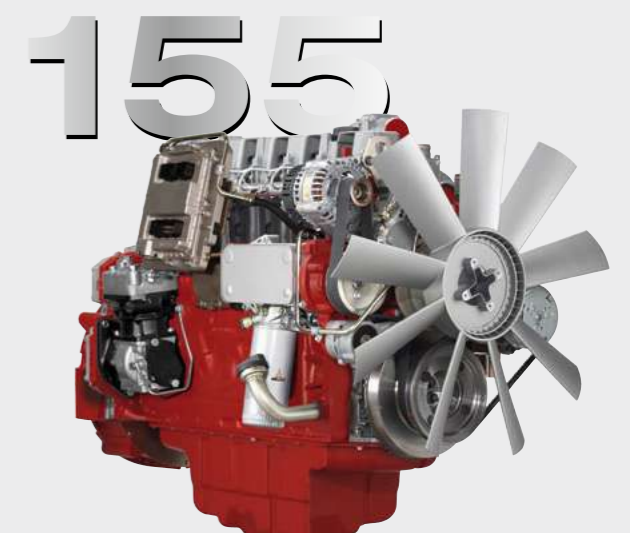

BFM 2012 75–147 kW | 100–197 hp
TCD 2012 67–155 kW | 90–208 hp

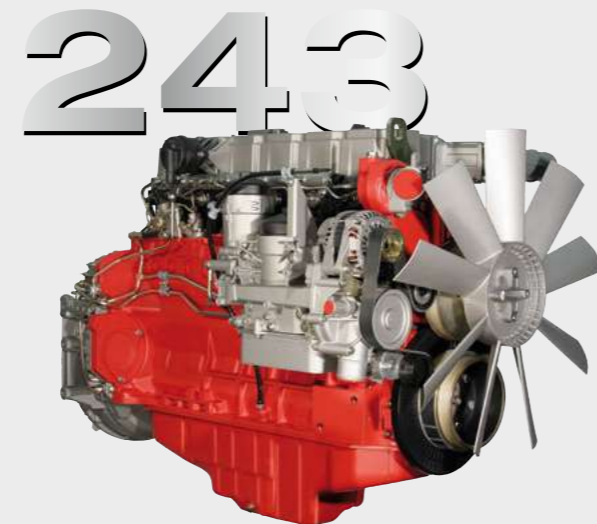

BFM 1013 63–200 kW | 84–268 hp
TCD 2013 75–243 kW | 102–326 hp

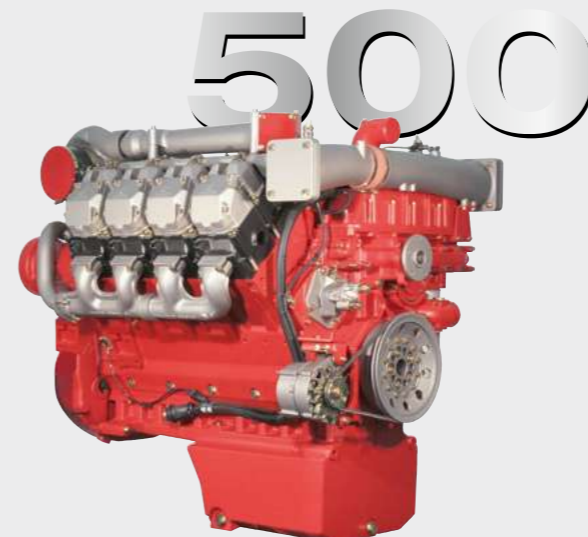

BFM 1015 187–440 kW | 251–590 hp
TCD 2015 240–500 kW | 322–670 hp

made by DEUTZ

Engines

STAGE
ready **V**

EU Stage IV / US EPA Tier 4

EU Stage IIIB / US EPA Tier 4 < 56 kW

The above data is given for the purpose of information only and does not represent binding values.

As an engine system supplier, we take pride in being specialists at solving complex drive requirements. Our job is to meet and exceed current and future exhaust regulations safely and effectively. With DVERT®, the variable emission reduction technology, we have developed a high standard of customized solutions for all engines to meet the latest emissions regulations in an efficient and economical way.

DEUTZ has a comprehensive product portfolio available for the emission stage EU Stage IV/US EPA Tier 4. With the Diesel particulate filter, our engines already meet the requirements of the EU Stage V Emission Standard, which is scheduled to take effect in 2019.*

55.4 97



TCD 2.9 L4 30-55,4 kW | 40-75 hp

TCD 3.6 L4 55,4-100 kW | 75-134 hp
TCD 3.6 L4 50-90 kW | 67-121 hp

115



TCD 4.1 L4 80-115 kW | 108-154 hp

180



TCD 6.1 L6 120-180 kW | 160-241 hp

250 390



TCD 7.8 L6 160-250 kW | 215-335 hp

TCD 12.0 V6** 240-390 kW | 322-523 hp

520



TCD 16.0 V8** 350-520 kW | 470-700 hp

* Based on a suggestion by the EU Commission COM (2014) 581 final, dated 25/09/2014

** Stage V requires additional aftertreatment

made by **DEUTZ**

Less Energy,

Scarce natural resources, sustainable environmental management, alternative drive technologies, and downsizing – the number of challenges and the range of potential solutions are huge. Only the innovation and knowhow based on many years of experience and partnership with our customers gives DEUTZ the technology leadership we enjoy today and be prepared for the future.

- Compact high-performance engines for exceptional handling and visibility with lower installation costs.
- Well-positioned auxiliary drives guarantee a wide range of efficient application options.
- High efficiency results and low fuel consumption based on high engine load factor.
- High resale value of DEUTZ powered machinery.

more **Efficiency.**



Engine integration

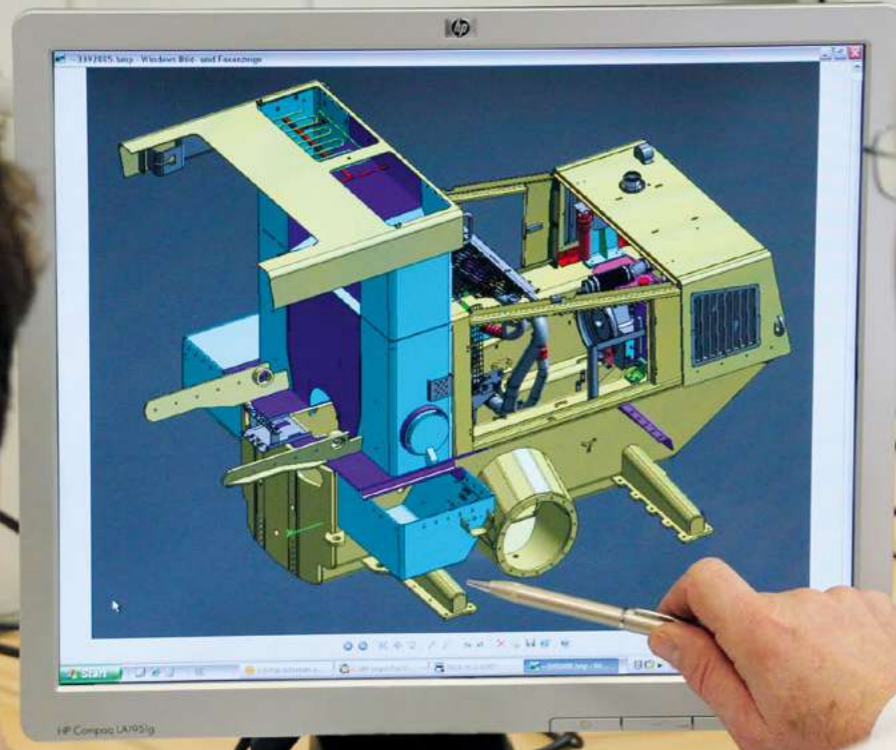



Performance



90 % of all DEUTZ customers remain loyal to their brand; here are some of the reasons why:

Reliability



 Spare Parts	 Maintenance	 Xchange	
DEUTZ SERVICE Life Time Support			 Service Network
 Emission Management	 Engine Plus	 e-Services	

Leading manufacturers

Each construction machine is only as good as its engine. That's why leading manufacturers choose DEUTZ. From installation and throughout the working life of the engine we are there for our customers.

With a complete portfolio of products and services we guarantee that "powered by DEUTZ" means one thing in particular – satisfaction.

- DEUTZ is one of the world's largest independent engine manufacturers offering a complete performance range from 25 to 520 kW.
- Sensitive customer data is secured with documented confidentiality.
- DEUTZ Service guarantees reliability and minimum operational down time.
- DEUTZ is expert in providing individually tailored service programmes

powered by **DEUTZ**





Not every engine can cope with so many applications – but every DEUTZ can.

Our customers demand a lot from our engines and the people who design and build them. Nearly 150 years of experience have taught us to listen and has given us the knowledge to have the right solutions ready to undertake the next challenge our customers may meet. Anytime and anywhere because we are: The engine company.

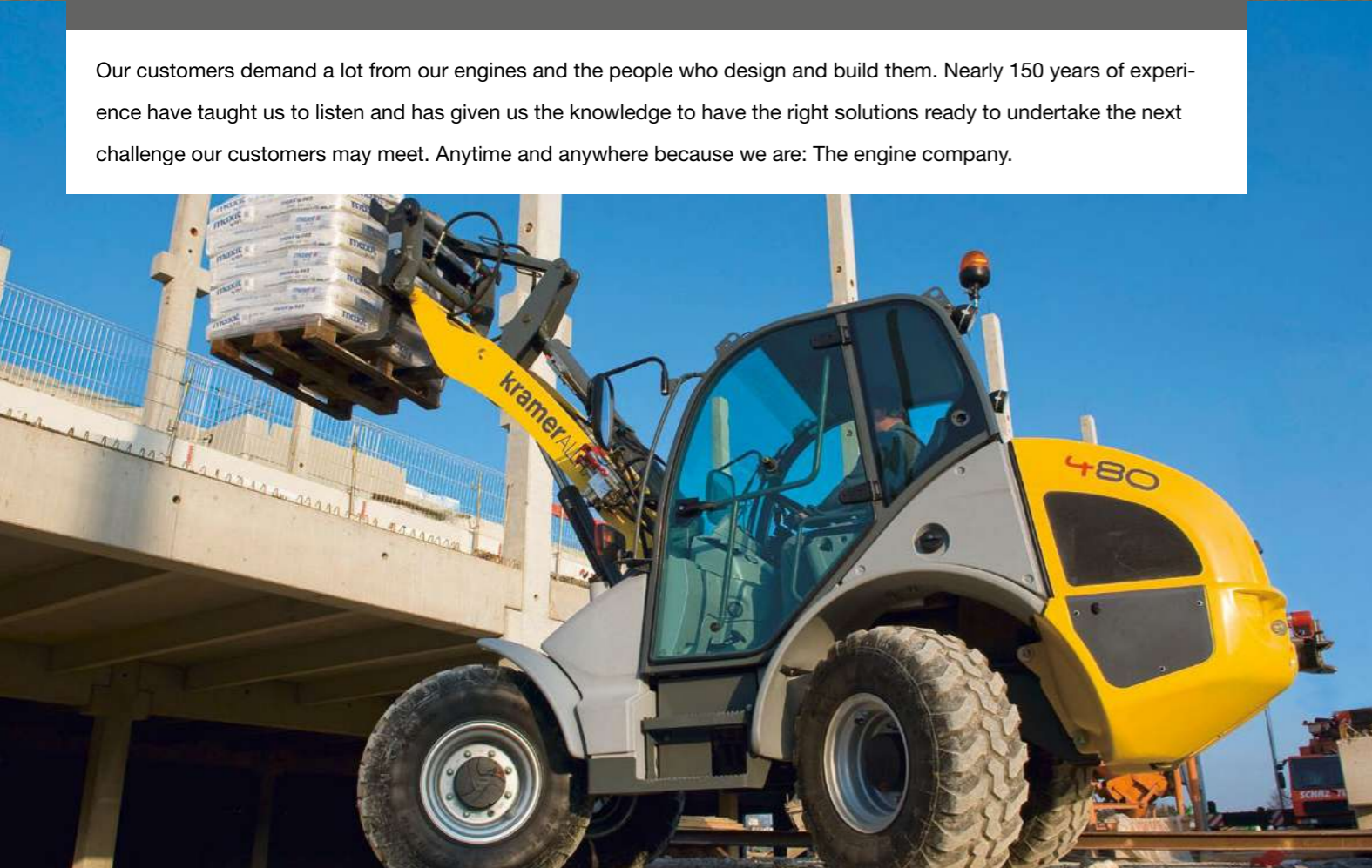

Haulotte, France



SANY, China



ATLAS WEYHAUSEN, Germany



JCB, England



SENNEBOGEN, Germany



worldwide:

DEUTZ AG

Ottostr. 1
51149 Cologne, Germany
Phone: +49 (0) 221 822-0
Telefax: +49 (0) 221 822-3525
E-mail: info@deutz.com
www.deutz.com

DEUTZ Corporation

3883 Steve Reynolds Blvd.
Norcross, GA 30093, USA
Phone: +1 770 564 7100
Telefax: +1 770 564 7222
E-mail: engines@deutzusa.com
www.deutzamericas.com

DEUTZ (Beijing) Engine Co., Ltd.

1102 CITIC Building
19, Jian Wai Dajie
Beijing 100004, China
Phone: +86 10 65 25 41 86
Telefax: +86 10 65 12 00 42
E-Mail: dbj@deutz.com.cn
www.deutz.com

DEUTZ Asia-Pacific (Pte) Ltd.

10 Gul Crescent
Singapore 629523
Phone: +65 66 72 7800
Telefax: +65 62 64 1779 / 62 65 3007
E-mail: dap@deutz.com
www.deutz.com.sg

DEUTZ Australia Pty. Ltd

Unit 4, 13-15 Brough Street
Springvale, Victoria 3171, Australia
Phone: +61 3 9549 8400
Telefax: +61 3 9549 8490
E-Mail: deutzoz@deutz.com
www.deutz.com.au

The engine company.

